

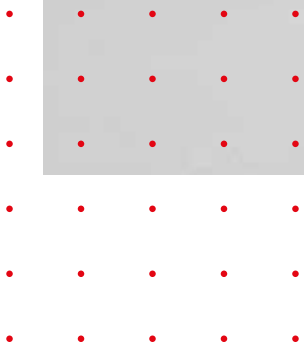

GUTMANN

EDITION #01/2023



# GUTNEWS

## *tuulo Relaunch*

As part of tuulo's refurbishment, we've gold-plated our brand design and given the tuulo website and app a fresh, bright, new look.

## *Cradle to Cradle*

In this interview: Max Radt, Head of Export at GUTMANN, explains the background and future prospects of the pilot project.

## *MIRA Hebe-Schiebetüren*

In Zürich, the city transport company VBZ and the Office of Public Works have built an architecturally striking extension to the existing bus garage with adjacent storage and maintenance facilities.

08 18 28

# WELCOME

# WELCOME

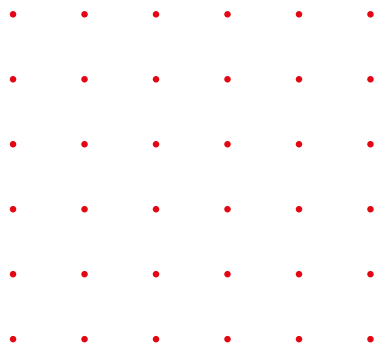

## Historic City Archives/ Stadtarchiv Cologone/ Köln, Am Eifelwall

*Systems:*

GUTMANN BAUBRONZE

GUTMANN LARA GF

GUTMANN MIRA contour integral

GUTMANN TWINLOC

---

*Architect:* Waechter + Waechter Architekten BDA  
PartmbB, Darmstadt

---

*Completion:* 2022

---

*Location:* Köln, Deutschland

---

*Builder:* Gebäudewirtschaft Stadt Köln

---

*Processor:*

Gebrüder Schneider Fensterfabrik GmbH & Co. KG

### LEGAL INFORMATION

GUTNEWS – Magazine for customers and partners of the GUTMANN Group

Nürnberger Straße 57  
D-91781 Weißenburg  
www.gutmann-group.com

### CONTACT THE EDITOR

Kati Benesch  
Tel. +49(9141)992-380  
Mail: gutnews@gutmann.de

### SOCIAL MEDIA

gtmnn.de/facebook  
gtmnn.de/youtube  
gutmann\_bausysteme

### CONCEPT & DESIGN

Design & Kommunikation  
im modulbüro

Siegbergstraße 73  
57072 Siegen  
www.modulbuero.de

### ILLUSTRATION TITLE PAGE AND PAGE 2

HISTORIC CITY ARCHIVES  
COLOGNE (KÖLN),  
AM EIFELWALL  
Image copyright:  
Brigida González

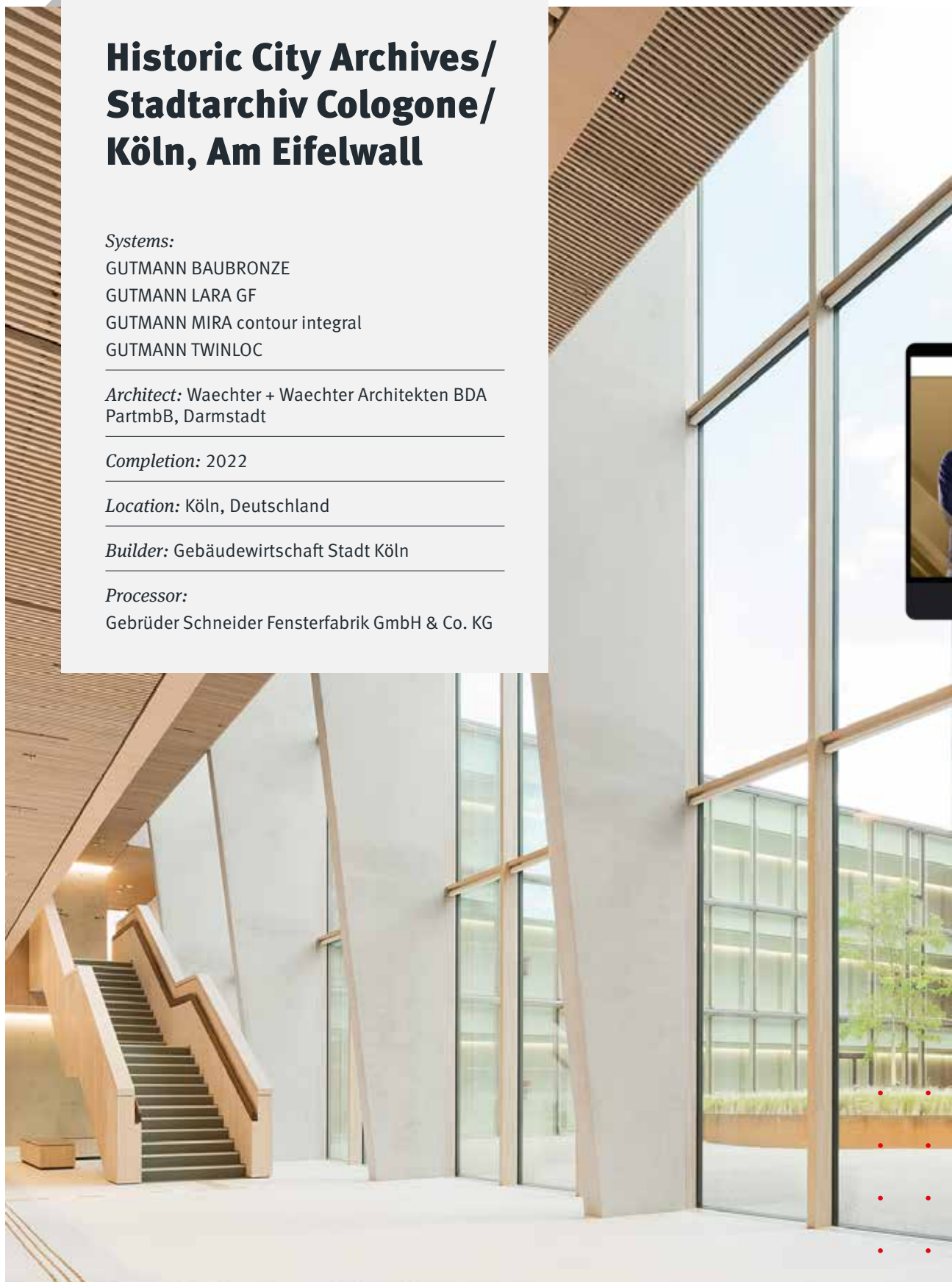

# CONTENTS

## 04 ...and action!

### *tuulo – action!*

Watch five brand-new clips featuring our familiar team of actors and see how our digital platform tuulo and GUTMANN products make the daily work of dealers and processors easier.



### *tuulo Relaunch*

In the context of the tuulo brand refurbishment, we've gold-plated our design and given the tuulo website and app a fresh, bright, new look.

## 09

### *Fall prevention devices*

FPS, FPA, FPS.I and FPS-K

### *Products*

- Curtain wall system wood-aluminium
- Overlap gasket LINE

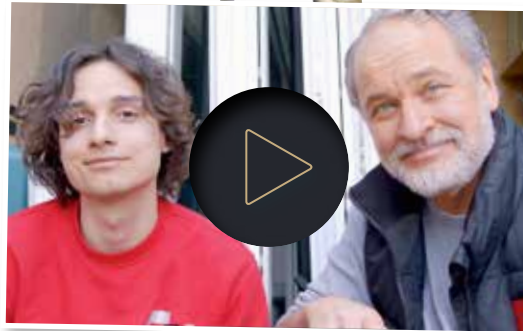

## 18

### *Cradle to Cradle*

- Interview Max Radt
- Interview Arnd Brinkmann

### *Project stories*

- Primary and Secondary School Vaterstetten
- Bus depot Zürich
- Haus Schwab

### *O&O Baukunst*

Architects talk

Manfred and Laurids Ortner



## 38

### *Themeday*

Efficient wood window production with high-performance partners

### *Trainee programme*

A career start with good long-term prospects





# LIGHTS, SOUND...

## ...AND ACTION!

*Over the past three months, we have set up our social media channels related to our digital platform tuulo and increased the frequency with which we add content – we now post regularly on Instagram, Facebook and LinkedIn. But we don't want to convince our users of the advantages of tuulo just with text and photos, but also with videos that show real action. We have already received some very positive feedback on the first tuulo clips, so we want to add more video content to highlight how our digital platform and GUTMANN products make the everyday work of window fabricators and dealers easier – in five brand-new clips featuring our familiar team of actors.*





# NEVER CHANGE A WINNING TEAM

When making te video, our main aim was to capture scenes and dialogues that resemble our users' everyday work as closely as possible. We found the right locations in Siegen: we decided to use an ordinary house where the windows were due to be replaced (our special thanks go to carpentry firm Schreinerei Klein-Nöh in Netphen, who made the active filming of their work possible). We were kindly permitted to shoot the office scenes at the same location as we used for the making of the previous video. Otherwise, we were working on a tight schedule: to ensure

that we could shoot three films in two days, we worked with three cameras filming at once – and could completely rely on “our” fantastic tuulo actors, who were at home in their old roles again immediately. Although a mere two days of filming meant a fair amount of stress, we had great fun working together on stage or behind the camera again. We're sure that that comes across in the videos, too. We will, of course, be using the new clips on our freshly optimised website and our social media channels, but we will also promote the videos using QR codes in classic print media.

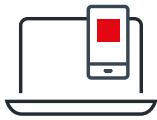

**Website**  
www.gutmann.de



**You Tube**  
gtmnn.de/youtube



**Facebook & Instagram**  
gtmnn.de/facebook  
gutmann\_bausysteme



**Print media**  
GUTNEWS



Watch the clip here



## REPLACING WINDOWS. CLEAN AS A WHISTLE.

*Day 1 - Film 1*

In our tuulo video “Replacing windows. Clean as a whistle.”, the master craftsman and his apprentice explain why fitting modern windows helps to save energy and protect the environment – and why house owners can sit back and relax when it comes to replacing old windows with new ones. Just like our master craftsman Hartmut, all window makers know that the world is full of windows and doors that have seen better days and leave much to be desired in terms of heat insulation. Shrunk gaskets or old double-glazing drive heating costs up. Too many resources go to waste unnecessarily because building owners do not know that they have a problem. Even if

old windows still appear to be intact, it is often the small details that make a big difference – even though general awareness of environmental protection and sustainability has rightly become a predominant issue for all of us in recent years. However, another reason why building owners often avoid replacing old, inefficient windows is because they are afraid that the procedure will turn their house into a dirty, noisy building site for days or weeks on end. These fears are allayed in the dialogue between craftsman and apprentice: with the necessary expertise and the right products, replacing windows is fast, easy, and clean as a whistle.

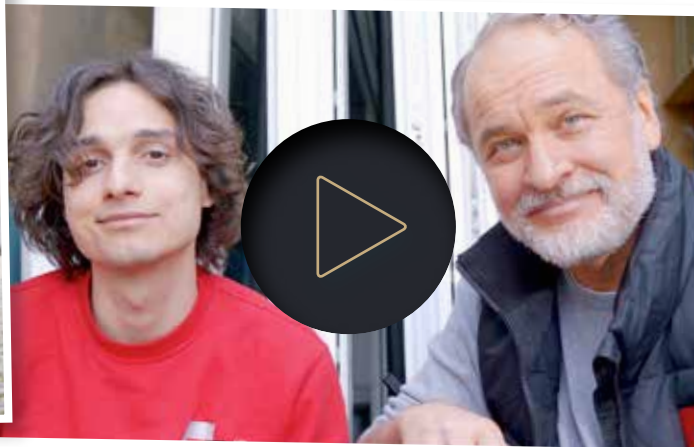

Up to date!

## ALWAYS “UP TO DATE” WITH TUULO.

During the tea break the other day ... in this clip, we show how tuulo saves users time and money. If customers have a query – about the order status, for example – all they have to do is look at our tuulo Customer Service Portal to find all the information they need. On the road, at another building site or even in their tea break. For window-makers, that means no more time-consuming calls to the office, the supplier or the customer. The digital tool already contains all the required information, which can be processed quickly and easily on a desktop

computer, laptop or smartphone. Window-makers can see at a glance whether the order is “in production”, “packed” or already “despatched”. Delivery dates, any delays, all commercial documents and the entire order history are also displayed. Anyway, our master craftsman is glad that he no longer has to make endless phone calls to chase important information. The bottom line: more time – but we leave it to our users to decide whether they want to use it to have another cup of tea or for some other important jobs...

Watch it here



## IT’S THE SHELL THAT COUNTS.

Triple glazing is good, but aluminium shells make it even better: In clip no. 3, master craftsman and apprentice look at the advantages of the aluminium shells on GUTMANN wood-aluminium windows. Their basic function is, of course, to protect the wood on the outside against the effects of wind and bad weather. However, the

high-quality processing and finishing of the shells are even more impressive: whether they are push-fit or welded, the corner joints and the frames fit perfectly. And while they’re watching, our viewers also learn about the various wood-aluminium window models and designs that GUTMANN has to offer.

Day 2 Film 1

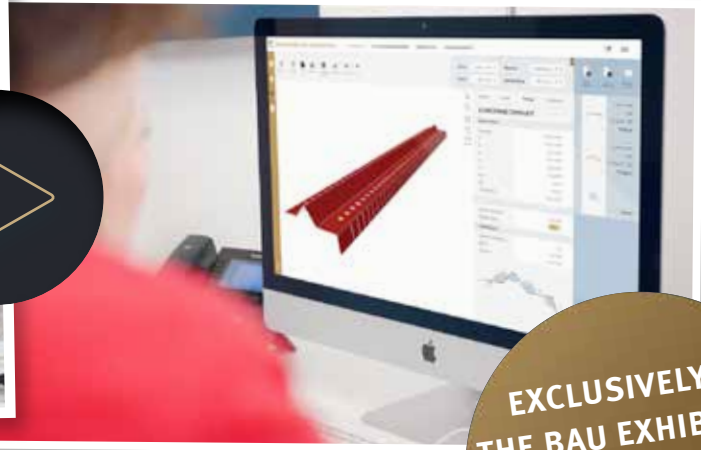

EXCLUSIVELY AT  
THE BAU EXHIBITION

Presentation of the beta  
version of the edging  
configurator

## EDGING. IMPRESSIVELY FAST ORDERING.

This tuulo video is all about the benefits of our new edging configurator. We chose a typical everyday scene in the office, where our apprentice is pretty flustered at first: he has to send GUTMANN an enquiry for a large quantity of edging with various dimensions all on his own. Jeanette calms him down by explaining that the new edging configurator allows the job to be done completely intuitively and in a user-friendly way, even with large

order volumes and a wide range of different dimensions. The system requests the necessary details one after the other, while gradually creating a 3D sketch to ensure that all data have been entered correctly, providing additional visual confirmation for the user and removing any need for additional sketches. In the video, our apprentice is mightily impressed – and in real life, window-makers will save a lot of time.

Jeanette explains here



## JEANETTE EXPLAINS TUULO.

Day 2 Film 2

In this clip, we look over Jeanette's shoulder as she works with tuulo – and we can see that everything is now even more user-friendly. All the news about the software itself is on the Start page of app.tuulo.de. In the Product section, the preview provides direct access to various functions, such as the Configurator or 3D data. Users save time by using the filter function for faster, targeted access ... all in all, the new design helps users to navigate faster and more intuitively.

Thank you!

A big "thank you" goes to the film team of FIU-MU GmbH from Siegen and "our" team of actors Hartmut Engel, Jeanette Bühren and Atalay Sahinbas. We would also like to thank carpentry firm Schreinerei Klein-Nöh for allowing us to film the window replacement, and photographer Ulrich Terschlüssen from imago in Olpe for taking stills on both of our filming days.

tuulo



# RELAUNCH

## NEW DESIGN, BETTER USABILITY

### DESIGN.

As part of tuulo's refurbishment, we've gold-plated our brand design and given the tuulo website and app a fresh, bright, new look. Window-makers and specialist dealers use tuulo as a digital tool the whole day, so we want to make sure they can find their way around website and app even more easily. Our priority was to concentrate even more on the people whose work is made easier by tuulo. For example, our "hero sliders" on the Start page is a new "golden" feature "which shows the main benefits of tuulo at a glance.



WWW.TUULO.DE

### USABILITY.

When it comes to software, user-friendly handling is worth its weight in gold. A more clear-cut, straightforward menu structure enables users to navigate more intuitively around the tuulo software. Barrier-free use was also an important consideration: by clicking on the corresponding button, users can switch to Dark Mode, which is easier on the eye. In addition, the improved Responsive Design ensures that website and app can be used on all device types. Highlights such as the Scan function are now even easier to find, so everyone will be able to enjoy all the practical benefits that tuulo offers.



APP.TUULO.DE

### FEATURES.

Now special tools and new features will be focused on immediately: Special graphics in a prominent position will be used to announce new features, such as the Edging Configurator (see next page). This also goes for our brand-new 3D Configurator, in which you can view, rotate, zoom and "touch" selected models of our wood-aluminium system MIRA and the classic wood-metal composite system SMART FRAMES in 3D. In addition, selected products will be presented in the Spotlight. There is a new supplementary feature for the tried and tested Window Sill Configurator, too: tabular rapid registration make it easier for users to order large quantities of window sills with different lengths.



3D.TUULO.DE



*Exclusive  
by tuulo!*

# GUTMANN

## FALL PREVENTION DEVICES

### FPS, FPS-K, FPA UND FPS.I

Floor-to-ceiling windows as a design element are gaining in popularity not only in modern office buildings, but also in private homes. Unlike balcony doors, they open into a void, so this type of window must be equipped with a special fall prevention system. One of the main concerns of modern architecture is to provide an unobstructed view outside without neglecting safety issues. GUTMANN has developed 4 solutions that fulfil the aesthetic and technical requirements of modern architecture. Modular, individually fabricated and tested solutions with an elegant, timeless design, complying exactly with your specifications.

CAPS,  
EDGE PROTECTION  
AND PROFILES IN A  
SINGLE COLOUR

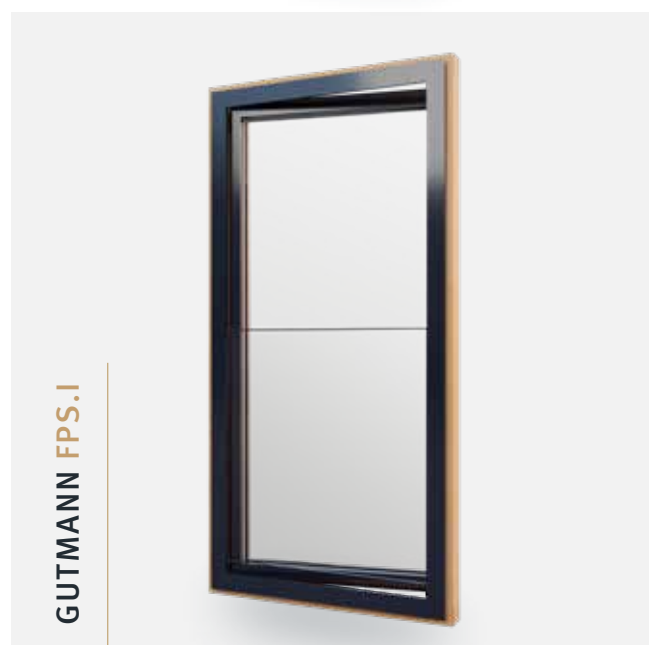
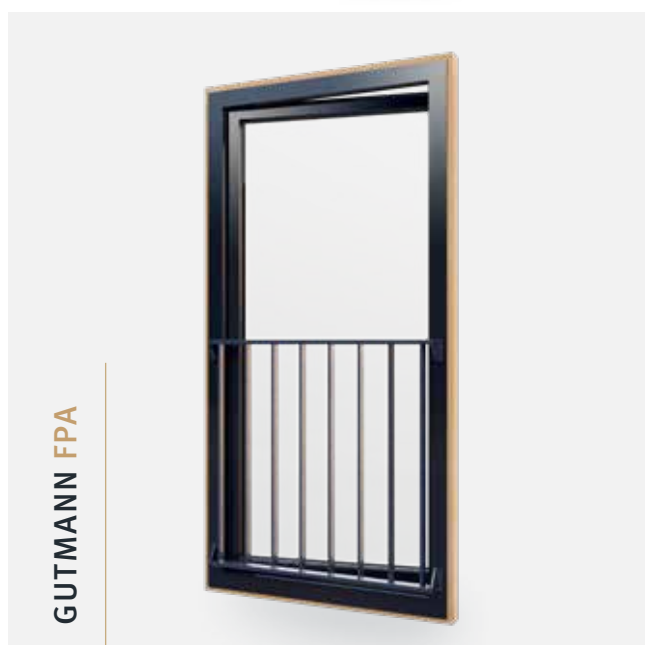
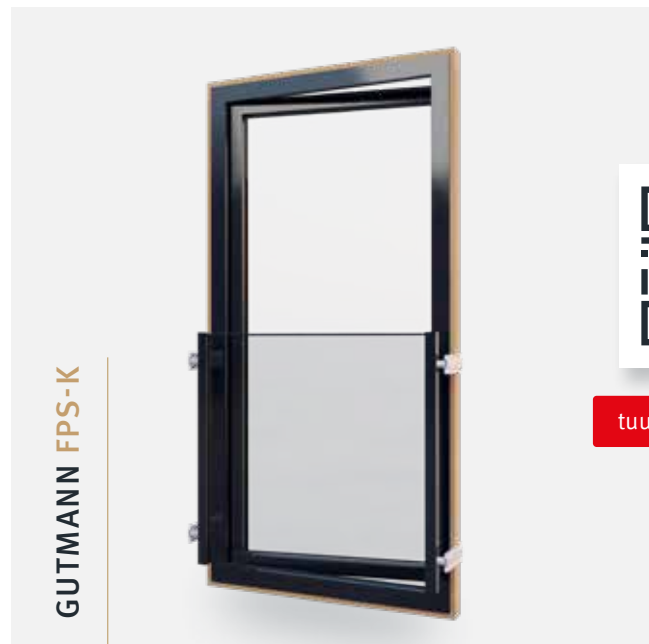

*Always  
up to date*



[tuulo.de/newsletter](https://tuulo.de/newsletter)

# GUTMANN FPS

- For mounting on all standard frame materials such as wood, plastic, plastic-aluminium, wood-aluminium and aluminium, regardless of system supplier.
- Heights between 350 and 1200 mm and widths from 400 – 3000 mm can be freely configured.
- Tested for all statically required glass thicknesses.
- All sets include pre-packed fixing material i.e., all fixing materials for the corresponding frame type.
- Fast, easy fixing without further mechanical processing.
- Concealed fixing.
- Prompt availability of in-stock standard colours RAL 9016, RAL 7016 GM and E6/EV1. Edge protection also available in EV1.
- Also available in all special colours on request.
- Uniform appearance of the entire fall prevention system, as the edge protection and cover are supplied in the same colour as the main profiles.
- Customer-optimised labelling with their commission and position details.

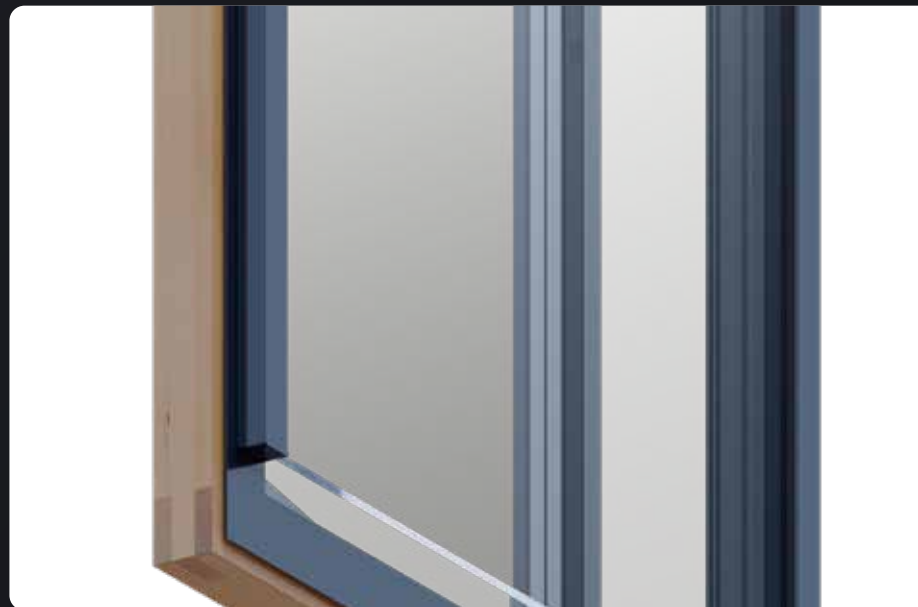

The GUTMANN FPS is mounted on the frame of the window element.

*Exclusive  
by taulo!*



Consoles are used to mount the FPS on the side of the frame. Additional functional elements such as insect screen systems, roller blinds, venetian blinds etc. can be fitted between FPS and window.

## GUTMANN FPS-K

- For mounting on frames made from wood, wood-aluminium, plastic and plastic-aluminium, regardless of system supplier.
- Heights between 500 and 1200 mm and widths from 500 – 2200 mm can be freely configured.
- Tested for glass thicknesses 12.76 mm and 16.76 mm.
- All sets include pre-packed fixing material i.e., all fixing materials for the corresponding frame type.
- Further functional elements such as insect screen systems, roller blinds, venetian blinds etc. can be fitted between FPS and window.
- Distancing achieved using consoles in the lengths 125 mm, 150 mm or 175 mm. Fast, easy mounting without additional mechanical processing of the FPS-K.
- FPS mounting brackets are concealed from view in the ETICS or bricks façade.
- Pre-assembled fall prevention bars delivered as standard save time for processors
- Prompt availability of in-stock standard colours RAL 9016, RAL 7016 GM and E6/EV1. Edge protection also available in EV1.
- Also available in all special colours on request.
- Uniform appearance of the entire fall prevention system, as the edge protection and cover are supplied in the same colour as the main profiles.
- Customer-optimised labelling with their commission and position details.

COMING  
SOON

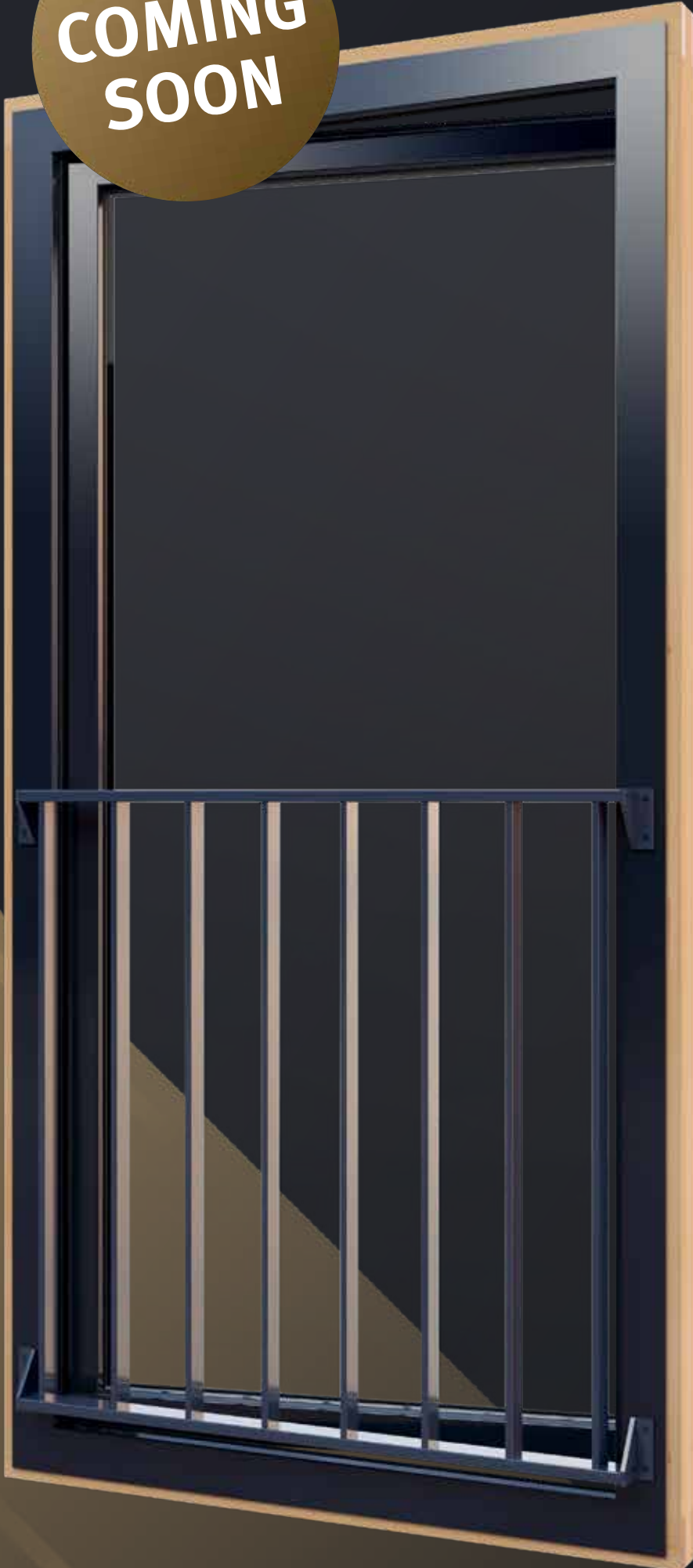

# GUTMANN FPA

- Aluminium fall-prevention grid.
- Filigree design.
- Distance between bars remains the same if overall width is changed.
- Available in mm-precise dimensions.
- All sets include pre-packed fixing material i.e., all fixing materials for the corresponding frame type.
- Fast, easy fixing without further mechanical processing.
- Prompt availability of in-stock standard colours RAL 9016, RAL 7016 GM and E6/EV1.
- Also available in all special colours on request.
- Uniform appearance of the entire fall prevention system, as the bars and cover are supplied in the same colour.
- Customer-optimised labelling with their commission and position details.

*Always  
up to date*



[tuulo.de/newsletter](https://tuulo.de/newsletter)

# GUTMANN FPS.I

GUTMANN's frame-integrated fall prevention system FPS.I was developed as an architecturally sophisticated solution for off-floor French windows and has been tested by the Buildings Inspectorate. Thanks to the system's integrated construction, all unsightly functional hardware is concealed by the aluminium shell. The transparent safety-glass pane is framed top and bottom only with an unobtrusive, filigree system edge protection profile. This innovative product combines transparency and safety in its elegant, timeless design and makes bulky additional safety structures superfluous.

- Available in custom-fit sets including the required accessories.
- Glazing can be replaced when frame is already fitted.
- Easy-to-assemble fixing technology.
- For all approved wood types in accordance with VFF Datasheet HO.06-1 | All wood thicknesses  $\geq 68\text{mm}$
- DIN 18008-4 compliance certification with Building Inspectorate (ABP) certificate available.
- All opening types open inwards and with comparable rabbet geometry.
- Rabbet geometries: Single, double and angled rabbet.
- Independent of the fitting system used.

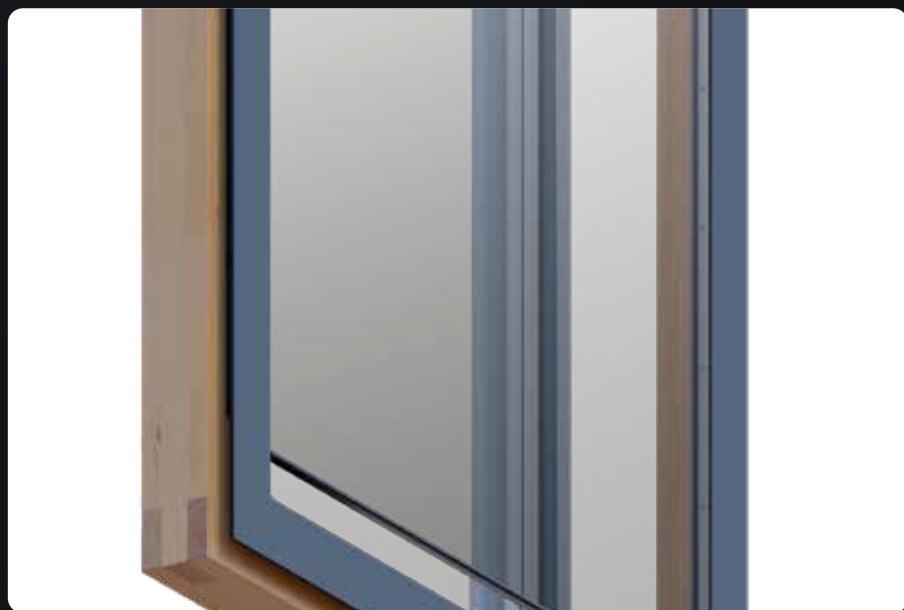

*Exclusive  
by taulo!*



Available to order  
online with tuulo

24/7

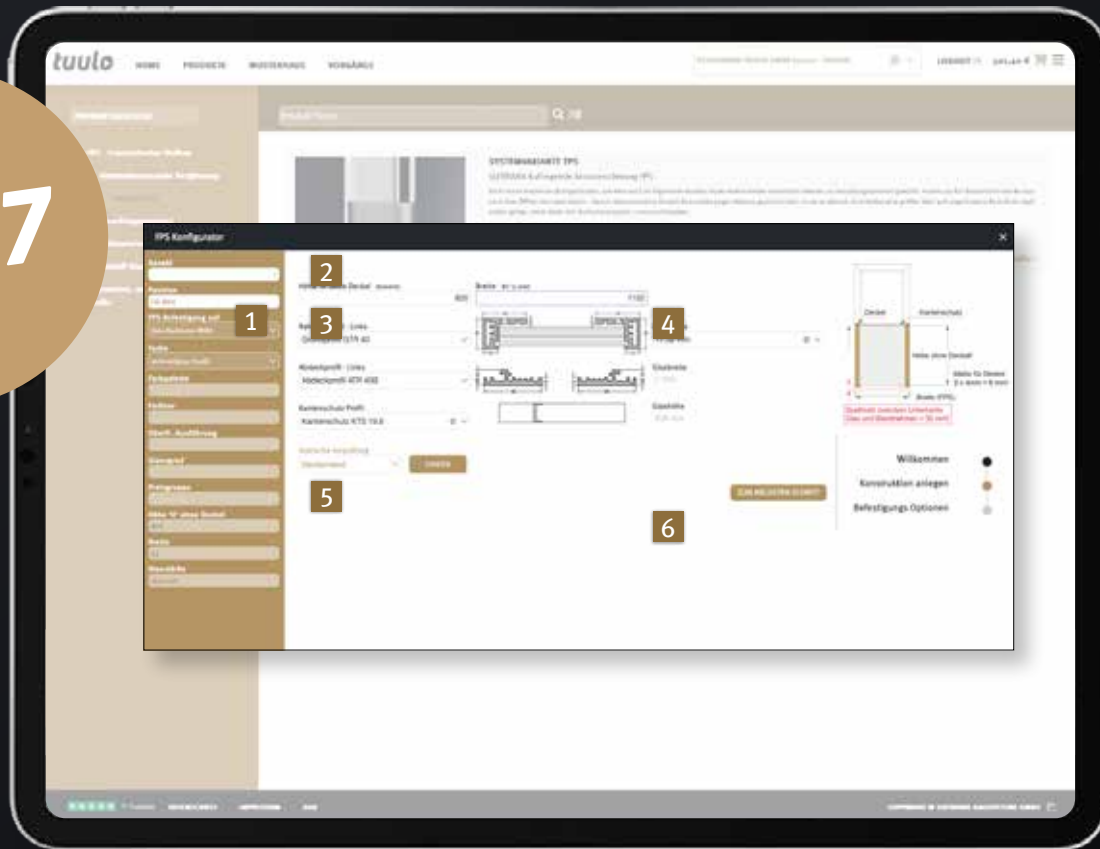

## ORDER WITH JUST A FEW CLICKS

Thanks to our smart Configurator, ordering our new FPS sets couldn't be easier. tuulo is the digital tool from GUTMANN with which construction systems for windows, doors and accessories can be planned and ordered extremely quickly on a computer or tablet. Only a browser window is required. tuulo provides information on items in stock, delivery times and order status.

- 1 Select system type and colour
- 2 Enter dimensions
- 3 Select frame profile
- 4 Select glass thickness, depending on the FPS required
- 5 Start static check
- 6 Add to shopping cart



Start FPS  
Configurator



Create your  
structure



Automatic  
check



Click! Add to  
shopping cart

# W&W CAMPUS, KORNWESTHEIM

*System:*

GUTMANN MIRA contour

GUTMANN Absturzsicherung FPS.I

---

*Architect:*

O&O Baukunst

---

*Completion:*

2018

---

*Location:*

Kornwestheim, Deutschland

---

*Image copyright:*

Stefan Müller

---



# PRODUCT

## Woodaluminium

### ■ FAÇADE SYSTEM WOOD ALUMINIUM – PRODUCT

*A new curtain wall system combining the aesthetics of wood and the properties and performance of aluminium. The best of both worlds in a single product.*

- Optimal performance figures
- Durability
- Adaptability
- High-quality workmanship
- Quick & easy fitting
- Sustainable sourcing



The two-stage system was awarded a “Winner” distinction in the category “Excellent Product Design” at the German Design Award 2023

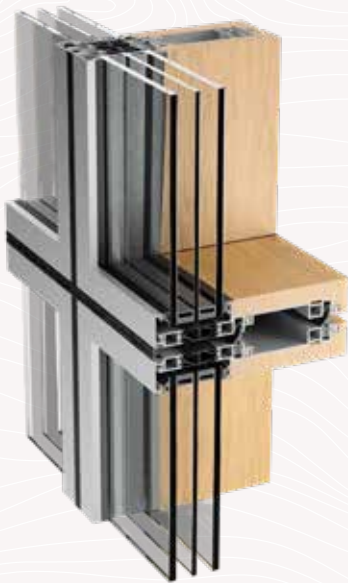

VERTICAL ELEMENT JOINT

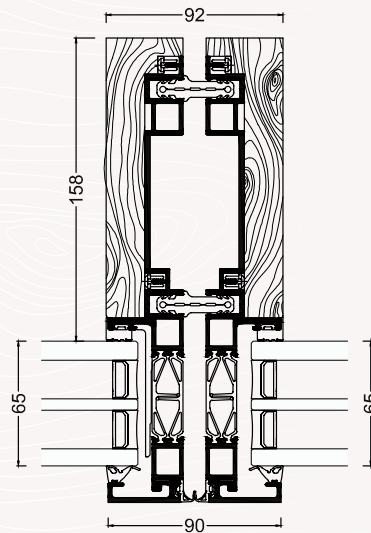

### HIGHLIGHTS

- Two-step mounting process
- Wood for static performance\* and aesthetics
- Partially recycled and recyclable
- Choice of different versions

\* All wood profiles are prefabricated and delivered by GUTMANN.

*For more information, go to:*

**GUTMANN-BAUSYSTEME.DE/  
UNITISEDFACADE**

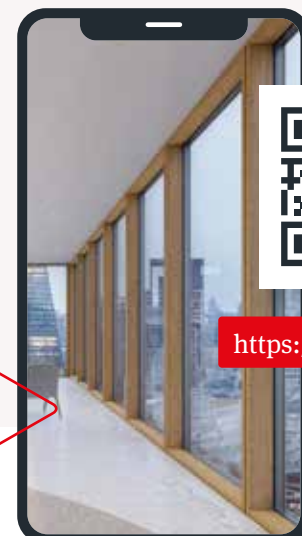

<https://bit.ly/3LsOvvP>





*New dimensions for new perspectives*

# OVERLAP GASKET LINE

## ■ WINDOW AND DOOR SYSTEM MIRA – OVERLAP GASKET LINE

*Use of the overlap gasket offers narrow frame and sash views*

- Use of the system gasket HA 1406 (Art. No. E006320) reduces the inside sash view.
- A visually flush view inside and concealed fittings are required for the overlap gasket GUTMANN MIRA line.
- Reduction of the sash view width by 10 mm.
- Can be used with all rabbet systems.



OVERLAP GASKET STANDARD

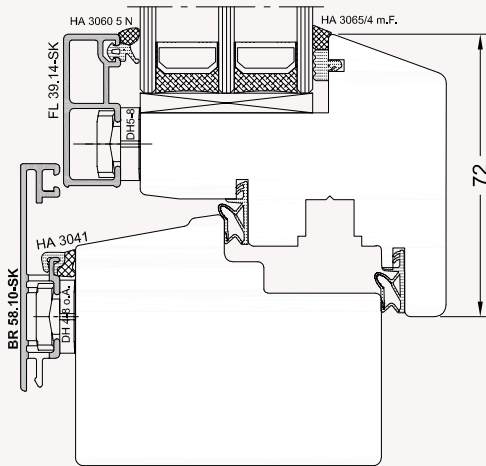

OVERLAP GASKET LINE HA 1406

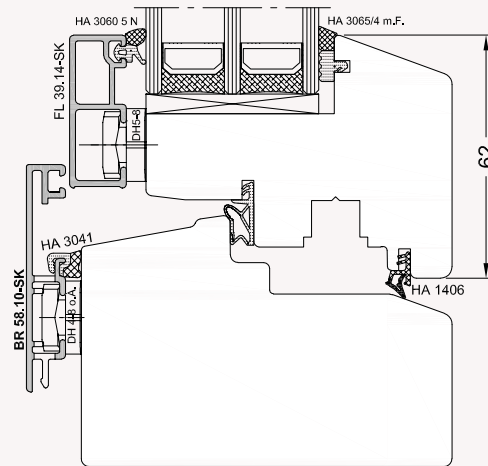

EXAMPLE SHOWN: WOOD-ALUMINIUM SYSTEM GUTMANN MIRA CONTOUR ANGLED RABBET

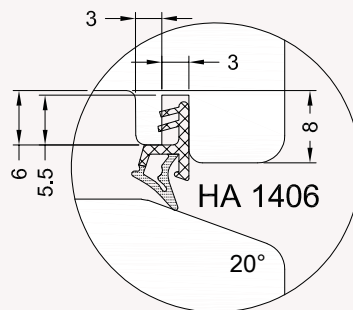
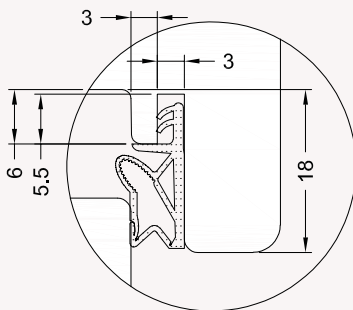

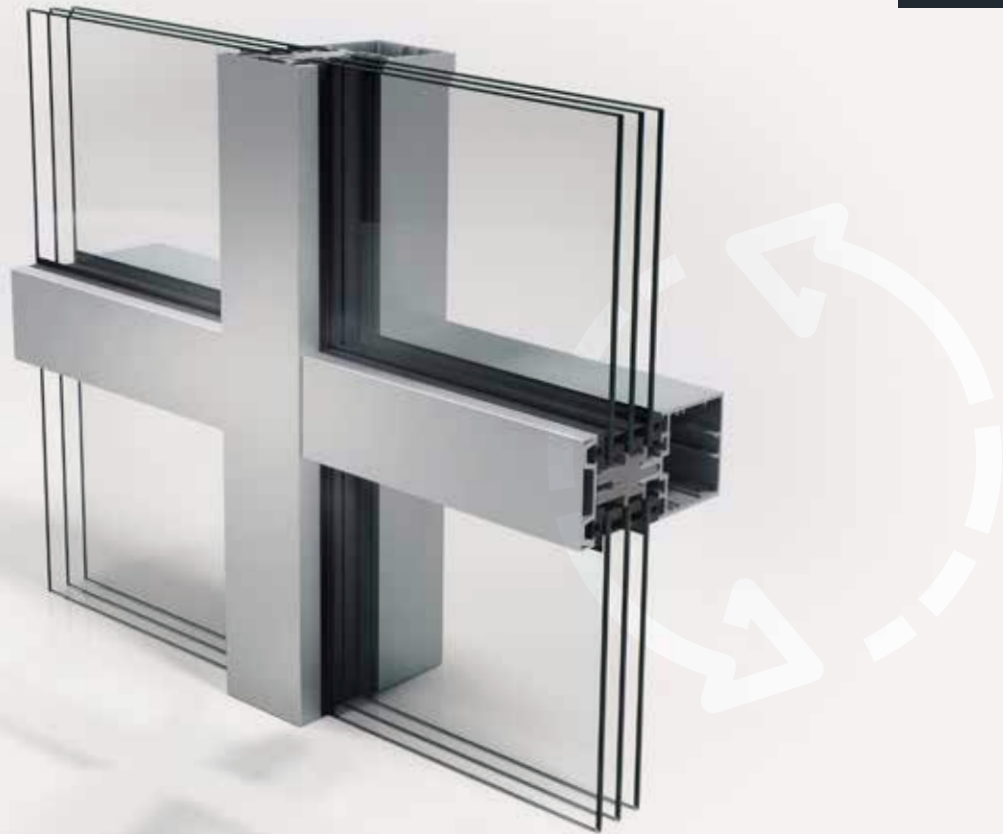

# INTERVIEW

## CRADLE TO CRADLE

### ■ INTERVIEW MAX RADT

*With its pilot project for the first cradle-to-cradle certification of a curtain wall system, Gutmann Bausysteme has just initiated a new era of future-oriented sustainability in the company and its product range – with a timeframe that is not interested in rapid marketing success, but in reliable long-term sustainability. In the following interview, Max Radt, Sales Director International Projects at Gutmann, explains the background and future prospects.*

Europe is aiming to be the world's first climate-neutral continent by 2050. Germany has set the bar even higher with its new Climate Protection Act, under which the country should be climate-neutral by 2045, five years before the rest of Europe. Looking at Gutmann Bausysteme in this context: What sustainability goals has the company set itself for the future? And what steps will characterise its sustainability strategy in the coming years?

**Max Radt:** Sustainability is always at its most efficient when considered from the very beginning of a process. That's why one of our goals here at Gutmann Bausysteme is to ensure that our sustainability strategy is implemented at the earliest possible stage of our production chain – during product development. Topics such as compliance with standards, statics, stability and durability, user-friendly mounting, as well as market potential and economic calculation used to feature high on the list at this stage. These topics are obviously still important, but in future, sustainability as a topic in its own right must be a permanent part of our specification sheet.

*Sustainability starts at the beginning of the production chain.*

And it doesn't stop at the aluminium elements we produce ourselves, but also extends to the big picture: in order to manufacture our products, we buy a wide variety of components from outside that, in turn, are made from an equally wide range of materials e.g., steel, hard or soft plastic gaskets, die-cast parts and much more. Depending on the system, the materials these components are made of can even be a bigger issue than our main topic aluminium. We also need additional materials for mounting our systems; although we do not supply them ourselves, we still have to factor them into the overall sustainability calculation for the design of a product. This includes adhesives, fixing materials, auxiliary resources and much more besides.

*The "Circular Economy Action Plan" is really one of the most important elements of the EU Green Deal: [https://ec.europa.eu/commission/presscorner/detail/de/ip\\_20\\_420](https://ec.europa.eu/commission/presscorner/detail/de/ip_20_420)*

Ensuring that the prefabrication level of our products is as high as possible is an important factor in determining the efficiency – and the consequent sustainability – of our work on the building site. And ultimately, the economic reduction of the number of components and materials used, and the aim of designing the simplest, most lightweight products possible are major contributions to their sustainability.

Even though it might initially sound paradoxical from the point of view of accompany that processes aluminium, we always strive – in the interests of resource efficiency – to use not as much, but as little aluminium as possible for our products.

It is clear, therefore, that sustainability and the circular economy will, in highly diverse ways and in many of Gutmann's development and production areas, play a central role in future. It is well known that the Circular Economy Action Plan, which was only published two years ago in March 2020, is one of the most important

elements of the European "Green Deal". And here at GUTMANN Bausysteme GmbH, we also want to join this new European agenda for sustainable, fair growth and a climate-neutral, resource-efficient economy.

*"For us, sustainability is not about marketing trends, but about our solid credibility as a family company."*

**MAX RADT**

**Cradle-to-cradle certification also plays an important part in the sustainability strategy at Gutmann Bausysteme. Why did you decide to pursue this particular form of sustainability certification?**

*Max Radt:* Cradle-to-cradle enables us to obtain direct sustainability certification for our products, so it is much more meaningful than the overall rating of a building, to which we can only contribute some, but not all, of the material. At the same time, the cradle-to-cradle certification process – which is very complex and comprehensive – is an extremely positive and productive way of compelling us to consider a large number of interrelated issues simultaneously.

This type of certification therefore generates a kind of snowball effect throughout our entire product development set-up.

As I see it, cradle-to-cradle is a very valuable principle that has occupied me for about two decades, dating back to when I worked as an architect. As a result, this current transformation from a linear economy to a consistently sustainable, circular economy at Gutmann is an issue very close to my own heart. Cradle-to-cradle is not just another certificate: It entails a fundamental, comprehensive rethink that will, in turn, assure the future of our company in the wider context of European and global climate goals.

**Which Gutmann curtain wall system did you choose to start this special certification process? And what made the system you chose particularly suitable for this cradle-to-cradle pilot project?**

*Max Radt:* We started our cradle-to-cradle pilot project with our Gutmann curtain wall system GCW 050/060. This is a mullion-and-transom system with a relatively small number of components; it is a fairly simple construction which can be assembled and dismantled comparatively easily. That also makes it easier to recycle the components. As GCW 050/060 is the system with the highest proportion of aluminium in our product range, it was the ideal way to highlight our main issue, aluminium, in the context of our pilot project. In addition, GCW 050/060 was thoroughly reworked and relaunched very recently, so it is perceived as an almost entirely new product, so the technological relaunch was also a sustainability relaunch.

*From a linear economy to a sustainable circular economy*

Another reason why it is particularly suitable for cradle-to-cradle-certification: We produce and deliver particularly large quantities of this system, so we also process a correspondingly large volume of aluminium. We have also designed a wood-aluminium mul-lion-and-transom version based on this system, which we would like to submit for cradle-to-cradle certification as the second step. Wood-aluminium is a particularly important future topic for us, so knowledge gained from this certification process will greatly assist us to focus even more on the potential promise of wood-aluminium in future.

**What benefits and characteristics make cradle-to-cradle product certification particularly valuable for a sustainable future?**

*Max Radt:* The particular value of a cradle-to-cradle certification process lies in its rich diversity: for example, DGNB or BREEAM explicitly require the use of a certain amount of material that has already been recycled. You could say that it is the other way round with cradle-to-cradle, where the future recyclability of the materials used is decisive – and aluminium, which is almost infinitely recyclable, is one of materials with the best possible rating. Basically, no aluminium is ever lost: it has a recycling rate of up to 95%, so most of the aluminium ever produced worldwide is still in use.

**What particular benefit does the cradle-to-cradle certification of your products offer not your company, but also – and above all – your customers?**

*Max Radt:* In recent years, the growing awareness of the impact of the climate crisis has ensured that the sustainability certification of “green buildings” is an increasingly upward trend.

*Aluminium has a recycling rate of 95%.*



**Max Radt**  
Head of Export

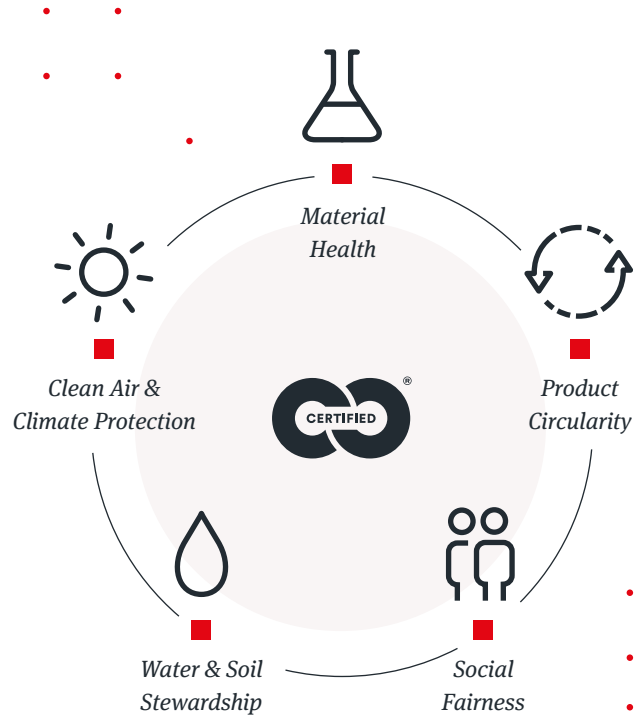

However, there is not much interest in sustainability certification in the construction industry yet. Instead, the interest is mainly among investors and property developers because sustainability certification firstly makes funding easier, and secondly allows the building to be marketed in a higher quality bracket.

So, like other forms of sustainability certification, cradle-to-cradle also generates clear added value for properties – a trend which will increase considerably as time goes on. Admittedly, the issue of sustainability certification is still relatively new. And as cradle-to-cradle certification is not based on an assessment of the finished building alone, but starts much earlier in the overall process – with the manufacturing of the basic products – it is an opportunity to make a valuable contribution to increased reliability and transparency of the certification of the completed building. In future, cradle-to-cradle certified products like ours can ensure that, say, an LEED-, BREEAM- or DGNB rating for a building can be obtained more easily and transparently.

This will give sustainable buildings a better marketing position than they have had up till now. Professional integrity and credibility are vitally important here; we are absolutely not interested in jumping on the bandwagon with hasty greenwashing, simply because the market has discovered that sustainability arguments are an eye-catching marketing tool. ■



# CRADLE TO CRADLE: THE NEXT GENERATION OF SUSTAINABILITY

■ THE NEXT GENERATION OF SUSTAINABILITY – INTERVIEW ARND BRINKMANN

*“In future, aluminium should no longer be part of the global environmental problem, but an intelligent part of the solution”, says Arnd Brinkmann, CEO of Gutmann Bausysteme. As a leading supplier of system-based aluminium solutions for buildings, Gutmann has therefore established a consistent, sustainable future strategy: with an efficient circular economy for the production and processing of aluminium – and recycling-oriented product design for forward-looking, cradle-to-cradle certified curtain wall and window systems.*

Aluminium is a fascinating material. For decades, its special characteristics and qualities have inspired engineers to create bold designs which combine lightness with high strength and durability – everything from aircraft and racing car construction to space-rocket technology and skyscraper architecture. The secret of aluminium – the light metal which has only been known for around 200 years since its discovery by the British chemist Sir Humphry Davy in 1808 – is its extremely low density of only 2.6 – 2.8 g per cubic centimetre. Processing is also relatively easy and economic, and aluminium is robust, impact-resistant, yet flexible and outstandingly weatherproof. On direct contact with oxygen, aluminium forms a tough layer of oxide which protects the material against corrosion and ensures the extreme longevity and durability of aluminium constructions.



## Will aluminium soon become scarce?

At first sight, there does not seem to be a scarcity of aluminium: as 8.1% of the earth’s surface consists of aluminium ore (bauxite), it is the third most common element and the commonest metal in the world. No fewer than 80 million tons of aluminium are produced every year, but global demand continues to rise steadily. At the same time China, a vast country that is severely impacted by environmental pollution, has significantly reduced production levels in its smelting plants, which meet about half of global aluminium requirements. And it has been clear – at the latest since the coronavirus crisis, which severely disrupted global supply chains and led to a severe shortage of aluminium resources – that aluminium is in danger of becoming a scarce commodity in future. As a result of the serious shortages on the global market, some experts are even talking about an imminent aluminium crisis.

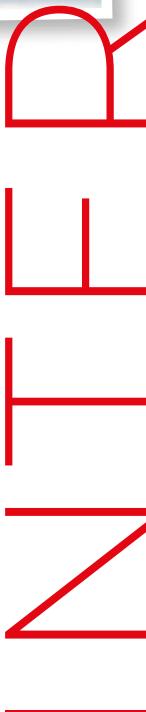

The latest development to give a drastic foretaste of an imminent aluminium shortage, and a consequent price increase for this valuable resource, is the continuing war in Ukraine. Since hostilities began in February this year, the prices for industrial metals have gone through the roof. At the end of last year and against the background of the coronavirus pandemic, the World Bank estimated that the price of aluminium would rise by around five per cent in 2022. This prediction has long since been overtaken by events – the price of aluminium already reached a record level in February 2022, passing the 4,000 dollar mark per tonne for the first time ever. The end of this trend is nowhere in sight, and it is actually accelerating due to the current state of the energy markets. The reason is that aluminium rarely occurs in its pure state, but is mostly found only in chemical compounds. Large quantities of energy are required for the extraction processes – and energy is currently more expensive than at almost any time in the past.

However, it is not only the looming threat that resources will become scarce, or the turmoil caused by pandemic and war, that are causing problems on the world aluminium market at the moment. The climate crisis and current efforts to make economies climate-neutral in future have put aluminium back in the spotlight of critical discussions; the fused-salt electrolysis process for the production of aluminium from mineral ore bauxite requires a lot of energy, and open-cast bauxite mining some of the ore-producing countries, such as Brazil or India, is a danger to the rainforest. Aluminium production also produces waste in the form of toxic red sludge which cannot be disposed of without a serious impact on ecosystems in the mining areas. These are issues which pose serious questions about the future of the global aluminium industry, for one thing is clear despite all the challenges: a future without aluminium would be a worse future. And discontinuing the use of this precious light metal for the next few decades would be unthinkable for many industries – from the aerospace and transport industry to mechanical engineering or the construction industry.



#### Recycling and renewable energy

The good news is that – despite all the current economic and ecological crises – aluminium still offers plenty of valuable future potential as a clean and sustainable raw material. Firstly, the high energy requirements of aluminium production can be cushioned to a large extent by using power generated from renewable sources. Secondly, aluminium is an outstanding material for recycling that can be reused in modern circular economy processes with no loss of quality and a recycling rate of up to 95% – using only 5% of the energy required for primary production of this versatile metal.



“One of the decisive factors in assessing the sustainability of aluminium is its origin, and the energy form that was used to produce it”,

explains Arnd Brinkmann, CEO of Gutmann Bausysteme. “On average, 15,700 kWh of electricity are needed to make one tonne of primary aluminium”, he says. “How this energy is generated is one of the most decisive factors when assessing the sustainability of aluminium production: In China, where most energy is generated from fossil fuels, around 25 kg of CO<sub>2</sub> are produced for every kilogramme of aluminium, whereas the corresponding figure in Norway is only about 0.5 kg CO<sub>2</sub> per kg of aluminium. Germany, with about 7 kilogrammes of CO<sub>2</sub> per kilogramme of aluminium, is currently in mid-table in the world rankings. Countries that generate most of their power from renewable sources are clearly the trailblazers here.”

#### **Cradle-to-cradle: product design for the generations to come**

The second important topic related to the sustainability of aluminium for Arnd Brinkmann is the use of the precious light metal in a consistently closed material cycle: “The most sustainable of all resources is the one that no longer needs to be produced – and recycled aluminium is about 95% more energy-efficient than primary aluminium. That’s why, firstly, we at Gutmann Bausysteme operate our own remelting plant, where scrap aluminium from our production is melted down and recast into high-quality aluminium ingots, which we then use to produce our aluminium profiles. And secondly, we are consistently recycling-oriented when it comes to product design. For example, our Gutmann GCW 050/060 curtain wall system doesn’t just offer excellent conditions for creative planning and outstanding construction properties – the system, with its consistently modular design, is also optimised for particularly efficient, rational manufacturing and has been awarded Bronze cradle-to-cradle-certification. This means that the product already meets important future standards in terms of decisive sustainability topics such as material health, material circularity, renewable energy, water & soil stewardship and social responsibility.”

For Arnd Brinkmann, the cradle-to-cradle principle – first drafted around the turn of the millennium by German chemist Michael Braungart and US American architect William McDonough – is one of the key elements of future sustainability strategy at Gutmann Bausysteme. In their book “Remaking the Way We Make Things”, first published in 2002, Braungart and McDonough defined cradle-to-cradle as a ground-breaking product manufacturing philosophy which only permits two types of product for a sustainable future: consumer goods that are entirely biologically degradable, and utility goods that can be endlessly recycled without loss of value or quality. With its cradle-to-cradle Bronze certification, the Gutmann GCW 050/060 curtain wall system falls



**Arnd Brinkmann**  
CEO GUTMANN Bausysteme

under the second category, as its easy-to-dismantle aluminium components are fundamentally designed to be infinitely recyclable. The dismantled aluminium elements are made of a “permanent material” and returned to the continuous recycling process, so every aluminium component installed in the system today is also a precious raw material store for tomorrow. “Our view is that, in future, aluminium should no longer be part of the global environmental problem, but an intelligent part of the solution”, says Arnd Brinkmann, “So by using innovative systems like Gutmann GCW 050/060 today, we are already laying the foundations for the sustainable architecture of tomorrow. In Germany alone, the construction industry is responsible for about one-third of today’s energy consumption and CO<sub>2</sub> emissions, and for more than half of all the waste produced. All the more reason to take our common responsibility for a sustainable future for the building trade even more seriously – because the buildings we build today will define the environment and living conditions of future generations for decades to come.” ■



[www.gtmnn.de/gcw](http://www.gtmnn.de/gcw)



*More about the GCW 050/060  
Aluminium curtain wall system*

RECYCLING-  
RATE (%)





The image shows a bright, minimalist interior space. On the left, a large window with a wooden frame looks out onto a balcony. The wall is white, and the floor is a light grey. To the right, a staircase with a white metal mesh railing and a white support pillar is visible. The lighting is soft and even, highlighting the clean lines and materials of the architecture.

APARTMENT BUILDING

# BORNHOLMER- STRASSE, BERLIN

*System:*

GUTMANN MIRA contour

---

*Architect:*

Appels Architekten GmbH

---

*Completion:*

2022

---

*Location:*

Berlin, Germany

---

*Image copyright:*

Simon Menges

---

*Builder:*

NKA Arnimhof GmbH & Co KG



# FLOOR-TO-CEILING WOOD-ALU WINDOW ELEMENTS

## ■ VATERSTETTEN PRIMARY AND SECONDARY SCHOOL – PROJECT STORY

*In summer 2019, the Karl Böhm Primary and Secondary School in Hans-Luft-Weg in Vaterstetten welcomed its first pupils. The extensive facilities also include a triple indoor sports centre and an indoor swimming pool. The characteristic outward appearance of the school buildings is enhanced by the façade, with its floor-to-ceiling wood-aluminium window elements from the Gutmann MIRA Contour series.*



600 or so pupils can use a total of about 8,500 m<sup>2</sup> floor space in the four buildings that make up the school complex. The buildings were planned by the firm of architects balda architekten GmbH (Fürstenfeldbruck), who won the local authority's tender for the work. The school complex is divided into three three-storey buildings. Each school is housed in a separate building so that the pupils do not get in each other's way. The schools are connected by a central Foyer, from which the three parts of the building can be accessed both horizontal and vertically. This area, which features bench steps and skylights, can be used as an event location for up to 800 people by connecting it with the music room and multi-purpose hall.

In their project documentation, the architects describe the external appearance as follows: "The school building presents an open and transparent external appearance. The ground floor, which is set back, supports the two upper floors, of which the projecting emergency exit balconies surround the actual outer wall like a protective shell. The fixed white slats, which are coated on one side with five finely nuanced shades of red and violet, are

particularly eye-catching. Depending on the angle they are viewed from, the colours change and the outward aspect of the building changes with them. Behind the slats, the floor-to-ceiling wood-aluminium element façade is broken up at irregular intervals by blank surfaces covered in pre-weathered silver fir cladding. The façade, with its floor-to-ceiling glazing, offers constantly changing views of the school buildings." Wood also plays an important role in the design of other parts of the complex. For instance, the façade of the building that houses the swimming pool on the ground floor and the gymnasium above it also features a silver-fir shell with offset bars in combination with translucent glazing.



# PROJECT STORY



The new school building was designed to reflect the requirements of modern education – a departure from schools with endless corridors and lecture-style teaching in favour of learning and team houses with alternative forms of teaching. The form rooms for the various years, multi-purpose rooms and the areas containing the lunchtime and all-day supervision rooms are grouped around a small “market square” with niches in the walls and different types of seating. The idea is that pupils can sit and chat, discuss, learn or read in small groups. The overall architectural concept of the complex is characterised by ample daylight, which in the case of the classrooms is provided primarily by the floor-to-ceiling wood-aluminium window elements supplied by Gutmann Bausysteme GmbH.

The contractor and the architects decided to use the MIRA contour system, with its characteristic geometrically clear-cut, rectangle-based look. The narrow frame design lets plenty of daylight into the classrooms, as the planners intended. With its  $U_w$  value of  $0.82 \text{ W/m}^2\text{K}$ , this system also meets the requirements for high energy efficiency.



# PROJECT STORY





# MIRA LIFT & SLIDE DOORS IN ZÜRICH BUS DEPOT

## ■ ZÜRICH BUSDEPOT – PROJECT STORY

*The city transport company VBZ and the Office of Public Works have built an extension to the existing bus garage with adjacent storage and maintenance facilities. The striking architectural features of this development project include lift & slide doors from the MIRA series supplied by Gutmann Bausysteme (Weißenburg).*

The striking form and characteristic concrete façade of the complex, finished in 2020 and located near Zürich's Letzigrund Stadium, catch the eye immediately. The firm of architects in charge of planning, pool architecten from Zürich, describes the idea behind the building as follows: "The load-bearing structure made of concrete poured on site forms the shell of the new building and determines its external character. The volumetric distribution of the old building also dictates the spatial distribution of the new building: VBZ's bus garage is extended by an annex corresponding to one layer of space. The ground floor of the annex is a manoeuvring area which can be used in a variety of ways, while the bridge-like protrusion of the upper floor contains the staff rooms and offices of Zürich's waste disposal and recycling company ERZ, which are arrayed along a narrow atrium. The road salt silo, whose tower-like superstructure supports and conceals, is also integrated into the ensemble."

### **Homely atmosphere inside**

The entire complex, which is 55 metres wide and 70 metres long, houses the ten-metre high garage for VBZ's buses and the three-storey ERZ storage and maintenance facilities. While the external walls and the 20-metre high salt silo are dominated by the structure of the concrete

with its striking formwork pattern, the staff rooms and offices inside are characterised by warm, light-coloured timber and reddish-yellow maritime pine fittings and furniture. The rooms on the 1st floor abut onto the bus garage and feature porthole-shaped windows to the outside and large wood-aluminium sliding doors to the courtyard between staff wing and garage. The cloakrooms, washing and shower facilities, utility rooms and generous recreation area are also located here. "It's important not to equate waste disposal with completely functional, austere design", says pool partner Andreas Sonderegger. "We wanted to create a homely atmosphere for everyone who works here".

### **MIRA lift & slide doors for more daylight**

It was important to retain the characteristic wood-finish look on the glazed side facing the courtyard on the first floor, so the architects chose wood-aluminium lift & slide doors from Gutmann Bausysteme's MIRA series for the exits here. They offer maximum glass areas with a minimal frame view, and the material combination of aluminium externally and wood internally enhances the architects' idea for a design that is robust on the outside and homely on the inside. This effect is further enhanced by the concealed hardware. Access to the courtyard from the recreation area is easy thanks to the MIRA lift & slide elements, and their high proportion of glass surfaces also admits extra daylight.

### **About the company**

GUTMANN is now a globally active group of companies and a leading manufacturer of high-quality aluminium products for the construction and processing industries. The group includes Gutmann Bausysteme GmbH and Gutmann AG with its subsidiaries Gutmann Aluminium Draht GmbH, Gartner Extrusion GmbH and NordAlu GmbH. The group employs around 1,300 employees at three production sites in Germany and has an average annual turnover of approx. 340 million euros. The company, which was founded in 1937, is based in Weißenburg in Bavaria.





# SPECTACULAR INTERPLAY BETWEEN WINDOWS AND FIXED GLAZING

## ■ HAUS SCHWAB – PROJECT STORY

*If detached houses are given several pages of coverage in the architectural trade press, they must be something special. The new build known as “Haus S” in Kottgeisering, a small community north of Lake Ammersee, is no exception. The first eye-catching features are the striking windows and fixed glazing in the façade. Gutmann’s wood-aluminium system MIRA contour integral was used here.*



# PROJECT STORY



Visitors approaching the house along the gravel drive are given their first enticing view of the interior of the ground floor through a large, square pane of fixed glazing in the north façade. The letter “S” in the name of the house is the initial of the surname of the family who live there. The owner is an architect himself, although Haus S was planned by Felix Huber (Kempten). “Of course, when the developer has studied architecture himself, the mind-sets are similar”, says Felix Huber. He and the developer worked together on the house in a process lasting five years. The architect sums up his firm’s design philosophy as follows: “Our firm conviction is that everything should be reduced to essentials. Straightforward, ecology-minded building is an antithesis of our technology-driven daily lives.” He consistently put this guiding principle into practice when planning and executing the design of Haus S. The house, which only occupies 91 m<sup>2</sup> of land, stands in Kottgeisering in 1,300 m<sup>2</sup> of grounds between two old villas. The 227 m<sup>2</sup> of living space for the family of four is a result of it being over 10 metres high and having three floors. The free-standing location of the house provides the perfect setting to display the hexagonal cubature of the house and its characteristic façade to full effect.

Two fundamental design features characterise the outside of the house. The walls are covered with classic rough-trowelled plaster similar to that used on the walls of the neighbouring villas; the surface structure was approved by the responsible heritage conservation authority and the work carried out by a single plasterer. The effect of the resulting façade is as creative as it is harmonious and consistent. The windows are the second character-

istic style element. True to the principle of clear-cut lines and “reduction to essentials”, both the architect and the developer chose the Gutmann system MIRA contour integral. Among the convincing features of this wood-aluminium system are its narrow frame view with completely concealed sash up to the insulated glass pane, and the high incidence of daylight enabled by the design. The integral windows are ideal for use in modern buildings like Haus S, and allow a wide range of versatile solutions for architecture at the highest technical level.

This is plain to see in the interplay between windows and fixed glazing elements. The fixed glazing is fitted flush with the plaster façade, so the aluminium profile is clearly visible. In contrast, the windows with opening casements are mounted deeper in the reveals and the outer shell plastered over. Alternating between these two installation techniques lends fascinating variety to the façade, but without disturbing its overall harmony. The Gutmann (window) elements were expertly installed by Gütthler Glasfassaden GmbH (Lauben). Gütthler has more than twenty years of experience in curtain wall construction, and the company is a specialist for systems in which wood plays a prominent part. As it says on Gütthler’s website: “We use up-to-the-minute processing technology to create functional, modern products that enhance the special character of wood as a building material”. The work done on Haus S with the wood-aluminium elements of MIRA contour integral from Gutmann is a typical example of how this aspiration can be implemented with optimum effect.





# PARTNER

## MORE THAN FIVE DECADES OF PROFESSIONAL COOPERATION

■ VBH DEUTSCHLAND AND GUTMANN ENJOY JOINT MARKET SUCCESS – PARTNER REPORT

*In this day and age, stable business relations based on quality products and processes, characterised and shaped by dedicated people, are worth their weight in gold. The decades-old cooperation between GUTMANN and VBH Deutschland is a shining example.*

Following the relaxation of Covid restrictions and the resumption of normal visiting, delegations from VBH’s sales, product management and logistics departments were welcomed to GUTMANN. At last, it was possible to meet in person and continue the well-established pre-pandemic tradition of partnership and collaboration to exchange technical innovations and business trends. They were followed in November 2022 by the Managing Director, Head of Sales and Head of Purchasing of VBH, who were on site in Weißenburg to discuss common strategic goals - and ways of implementing them – with senior managers from GUTMANN.

### Who are VBH?

The VBH Group is Europe’s leading trading house for window and door fittings, with 14 sales locations and three logistics centres throughout Germany and 23 international subsidiaries. For decades, the company from Korntal-Münchingen has offered window- and door-makers, fitters and decision-makers a complete range of products for the manufacturing and expert fitting of wood, wood-metal and plastic windows and doors. Around 35,000 brand-name products and the company’s own-brand greenteQ products are permanently in stock for immediate despatch.

### Continuous expansion

The initial cooperation between VBH and GUTMANN was on a fairly modest scale. On the basis of the GUTMANN building hardware products available at the time, the links with VBH began via GUTMANN’s external warehouse in Zuffenhausen. Peter Frank, who was then active in the market with a trade agency, developed and continuously expanded the contact with VBH. Window-makers got to know GUTMANN’s products on site at VBH’s in-house regional trade fairs. Peter Frank and his four-man team of field salesmen managed to make GUTMANN products a familiar sight in the north of Germany, in addition to their existing popularity in the south. GUTMANN’s presence at major trade exhibitions (such as the Ironmongery Fair in Cologne or the Trades & Crafts Fair in Munich) cemented the already flourishing relationship. Time and time again, these events served as creative encounters between system supplier GUTMANN, specialist trader VBH and the processing industry.

### Customer potential identified

The partners jointly set up various wood-aluminium systems (System 600 rebated, System 1000 flush-fitted and conservatory system 2000) which they gradually launched on the market. Both GUTMANN and VBH quickly realised that there was a lot of potential with processors here. The systems were constantly developed – a development which still continues today. As the VBH location network grew, so did the scope of the two companies’ collaboration and their pool of expert knowledge. Issues raised and remarks made by processors were collected and incorporated into GUTMANN’s developments – a policy which continues without restrictions to this day.

### Investments and innovations promote success

The work on finer details was and is characterised by a regular, intensive exchange of ideas between the respective field sales teams at GUTMANN and VBH. The network has continued to grow, and the expansion of





business relations was largely a result of continued investments and innovative developments by GUTMANN, including:

- KASTO warehouse,
- horizontal / vertical coating facilities,
- Rahmenfertigung sowie Ausbau der Systeme und Sonderframe manufacturing and expansion of the systems and special solutions,
- start of sheet-metal processes (edging),
- new fall protection systems,
- new mullion-and-transom designs in conjunction with programming in KLAES (InOrder), Logikal, Tuulo etc.
- recruitment of additional skilled staff
- implementation of EDI (electronic data interchange) for standards, and Klaes master data for quotations / ordering.

#### Direct personal contacts

Although electronic communication methods and channels are becoming increasingly important, it is still the personal contact between the sales experts from both companies that characterises day-to-day business. GUTMANN's entire field sales team communicates actively with its VBH counterparts in the property sector and exchanges information about innovative developments, for example. The internal sales team at GUTMANN acts as the contact for VBH office and field sales staff when they need information about a delivery, prices, (for frames, bars, special profiles or properties). The design and application department in Weißenburg also provides support with solution details and, if required, will accompany the VBH processor on site.

#### VBH wood/metal department and GUTMANN on site with the customer

This special cooperative relationship directly on site with the processor is typified by the activities of the VBH wood/metal department. More than 14 members of VBH staff are dedicated exclusively to this product field; they are present throughout Germany to give individual, comprehensive advice and to provide solutions. These dedicated professionals in the field of technical advice offer a wide range of services – with the added support of GUTMANN experts where required – covering the following issues:

##### For wood/metal frames:

- Planning and execution of the aluminium elements
- Dimensional chain comparison with wood widths
- Determination of soundproofing and thermal insulation values
- Tips and tricks for more cost-effective manufacturing/fitting
- Comparison of RAL powder with other crafts (roller blinds/window sills...)
- Trial fitting on site
- Provision of hire tools
- Measurement of cover shells for renovation and preparation of profiles
- Generating orders and quotations (fall protection/frames/edging)
- Maintaining high delivery readiness at VBH e.g., for accessories to allow earlier production



##### For mullion/transom/curtain wall:

- Trial fitting on site
- Mounting and assembly instructions
- Provision of hire tools
- Creating drafts of façade views
- Offcut optimisation

##### For edging:

- Finding solutions for optimised water run-off at structural joints
- Advice on surfaces and surface finish
- Advice on building insulation

##### For fall protection:

- How are systems fitted, where is special attention required
- Trial fitting
- Advice on the services the company must provide
- Predetermination of glazing statics

##### Joint market assessment and customer approach

This tailor-made service package for customers with the ultimate goal of sustainable process optimisation sends a clear message: VBH see itself as more than just a wholesaler whose job is simply to distribute goods. For many years, VBH has acted according to the principle that merely “shifting goods from one place to another” or using the selling price as the main purchasing argument are not forward-looking solutions. On the contrary, it is vital to be actively involved in the development of products and services in order to discover added value for customers and offer them corresponding solutions. This strategy completely matches GUTMANN's attitude to the market – which is an essential condition for the success of the decades-old cooperation.

Optimising process flows in the highly competitive wood-aluminium market remains a daily challenge for both companies – cost calculation in conjunction with retaining customer loyalty require constant alertness and the continuous development of expertise. GUTMANN as a supplier and VBH as a specialist trader are prepared to face this challenge – always target-oriented, and always speaking a common language with the customer. ■

# ARCHIT

THE VIDEO  
IS HERE



<https://www.youtube.com/watch?v=ofyxdozAJRI>



Manfred and Laurids Ortner

## O&O BAUKUNST

### ■ O&O BAUKUNST – INTERVIEW

*Architekturbüro Ortner & Ortner Baukunst is a German-Austrian firm of architects which was founded by Manfred Ortner and Laurids Ortner in 1987 and is now run jointly with Roland Duda, Christian Heuchel, Florian Matzker and Markus Penell. The roots of O&O Baukunst go back to the Viennese art scene and architecture group Haus-Rucker-Co in the 1960s and 1970s. Their focus is on European architecture that combines a historical legacy with the demands of modernisation.*

According to Manfred Ortner, tomorrow's architecture will concentrate on fulfilling two requirements. The first, of course, will be to ensure that the design and construction of all buildings is environment-friendly and uses recyclable materials. The second requirement will be for all towns to achieve a certain level of energy autonomy to allow the entire system to endure. He also stresses that, although wood undoubtedly combines aesthetics and functionality with sustainable benefits, other recyclable materials are equally important. He cites recyclable bricks and concrete as just two examples. Science has an important part to play in the development of new materials and of ways to recycle them and minimise waste. Laurids Ortner states that architecture and building construction are approaching

the same level as the automotive industry with its large financial support and highly automated production. Increased industrialisation goes hand-in-glove with a transition to the highly automated manufacturing of goods. Smaller companies will not be able to survive the increased costs of converting to certified and circular products that fulfil stringent sustainability criteria. He believes that we should view sustainable architecture holistically, rather than simply focusing on the materials used. In Europa, we have made considerable progress in this area and can be proud of the many buildings constructed in accordance with the principles of sustainable architecture – and we must encourage the next generation and other countries to follow our example. ■



## O&O BAUKUNST ABOUT W&W CAMPUS

### ■ O&O BAUKUNST – INTERVIEW

*The Campus for W&W – Wüstenrot and Württembergische – is intended to unite various business sectors under one roof and provide a future-oriented working environment. The terraced campus blends into the existing surroundings and connects courtyards and garden areas with the individual buildings.*

Manfred Ortner describes the major W&W Campus project as a group of seven individually arranged courtyard buildings holding offices and a conference centre, which are connected by subways and overground pathways. The ensemble fits well into the lively existing topography of the area surrounding the entire campus. The complex, which provides a total of about 4,000 workspaces, is organised to guarantee optimal, sustainable working conditions in combination with an attractive, future-oriented working environment. He added that the Campus is sustainable in every respect, as 90% of it is made of brick; the buildings are surrounded and interspersed with “fingers” of green space, giving the impression that one is working in the heart of nature.

Laurids Ortner says that a broad path leading between all the buildings on the Wüstenrot and Württembergische Campus was created, a unique feature that connects all structural elements and ensures that all shared facilities are within easy reach. This path is the backbone of the project, offering an animated sequence of spaces that starts with the central square and progresses via steps and terraces that blend harmoniously with the overall topography. The newly built complex covers an area of 160,000 square metres. ■



“One successful feature of the Campus Wüstenrot and Württembergische is actually a broad path that leads between all the buildings in the complex.”

LAURIDS ORTNER, O&O BAUKUNST

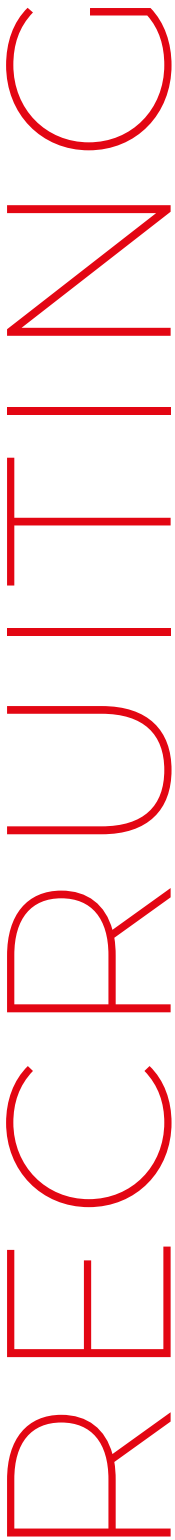

# TRAINEE PROGRAMME AT GUTMANN: A CAREER START WITH GOOD LONG-TERM PROSPECTS

## ■ CAREER

*They're young, ambitious and will soon be completing their degree: GUTMANN needs qualified young professionals to help us meet the challenges the industry faces, so we are actively recruiting talented graduates and offering them their own trainee programme. These young academics will receive 24 months of training in all sections of the company, with the long-term prospect of becoming tomorrow's in-house experts and managers.*

Where up-and-coming talent is concerned, we have chosen the right time – and the right topic. It is the time when young people have just left university and are about to start their professional careers and want to be involved in dealing with global challenges. In this age of climate change, many of the younger generation are motivated by the will to shape a clean, environment-friendly future. GUTMANN is a family firm where sustainability is not simply a marketing trend, but an ambitious corporate goal. We see man-made climate change as the greatest challenge of our time, so we are committed to giving young, talented people a chance to create a more sustainable future with GUTMANN Bausysteme. Our intelligent system solutions for windows, doors and curtain walls make energy-efficient building a reality, so we are actively involved in the energy revolution – and with our trainee programme, everyone at GUTMANN can play a part, too.

### Shape your future

Young graduates have the whole world at their feet, and we offer them an individually tailored trainee programme which encourages them to develop their talents and qualities with us and launch their professional career at GUTMANN. Tim Hanneforth, Group HR Director at GUTMANN, is proud of the result: "Our trainee programme is the ideal way to move smoothly from higher education to a top career in our company!" With the holistic development of its junior employees in mind, GUTMANN has designed a concept which ensures that university graduates can develop and nurture their talents to the full. To start the programme, all our new trainees are given a comprehensive insight into the entire company. After that, the projects and the main topics of their project phases are continually discussed and assessed. This enables trainees to develop their leadership qualities in practice.

Exciting team projects and inter-company seminars complete the programme.

This highlights what we consider important for the participants: everyone receives individual, project-oriented encouragement and support. GUTMANN treats them as equals and helps them to develop under the guidance of an experienced mentor, so every trainee can achieve his or her personal goals. After all, our recruiting motto is: Shape your Future.

### Four phases of success

The 24-month trainee programme is divided into four six-month phases. After a kick-off event to give newcomers a chance to meet, the trainees visit every part of the company in turn. The advantage here is that trainees can already start to build their own personal networks while continuously broadening their knowledge horizon. Trainees are free to choose their preferred project stations in the second and third phases, before completing the fourth phase of the programme with an appropriate final project. In addition, all participants in the programme can submit their final project for an external examination and certification, if they want. After that, there is generally nothing standing in the way of a transfer to the takeover department.

For more information, go to [karriere.gutmann.de](http://karriere.gutmann.de) or contact Mr. Tobias Setzer in person at: [setzer@gutmann.de](mailto:setzer@gutmann.de)

*Interested in the trainee programme?*



# Shape your Future

## 4 PHASES TO SUCCESS

### 1. STARTING PHASE

- Kick-off
- Basic familiarisation with the entire company Sales & Operations



### 2. PROJECT STATION A

Individually selected areas

- **Sales:** Advice & sales and/or
- **Operations:** Development & project management



### 3. PROJECT STATION B

Individually selected areas

- **Sales:** Advice & sales and/or
- **Operations:** Development & project management



### 4. FINAL PHASE

- Final project
- Transfer to the takeover department
- Optional: external exam / certification

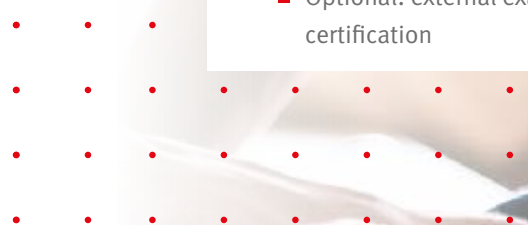



Left to right: W. Spohn (GUTMANN) / M. Deisel (WEINIG) / E. Tiefenthaler (LEITZ) / A. Binder (KLAES) / R. Drißner (DRISSNER Fensterberatung) / D. Eberhardt (WEINIG)

# THEME DAY

## EFFICIENT WOOD WINDOW PRODUCTION WITH HIGH-PERFORMANCE PARTNERS

Five high-performance suppliers for various aspects of window-making showed you the latest innovations in the field of wood and wood-aluminium window production and presented Gutmann's wood-aluminium systems, including the new Mira wood window system with sash cladding. These days, many partners are required before a system is ready for production: independent advisors,

software providers, makers of tools and machinery, and profile system suppliers need to be coordinated and combined. We will do the work for you and show you how all the steps in the window-making process are coordinated to achieve optimum results – and greater economic efficiency and success for you.

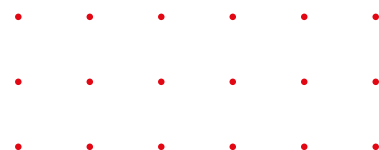



Copyright: Dittel Architekten GmbH



### *Wood windows with sash cladding – the system supplement between pure wood and wood/aluminium construction*

- Elegant, clear-cut design with no sash joints visible from indoors.
- Weather-resistant aluminium sash cladding guarantees exceptional quality and durability.
- Efficient manufacturing – no need for complicated production and installation of the glass strip. The glazing process follows the same procedures as wood/aluminium systems.
- Flexible manufacturing concept – profiling of the cover frame and sash is based on a combination of wood and wood/aluminium window, so execution with the existing tools is possible.können.

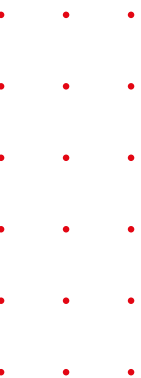

# GUTMANN

## THE GROUP



The  
GUTMANN  
Group

1 **NORDALU GmbH**  
Neumünster

2 **GUTMANN AG**  
**GUTMANN Bausysteme GmbH**  
Weißenburg

3 **GARTNER EXTRUSION GmbH**  
Gundelfingen



EMPLOYEES

**1.480**

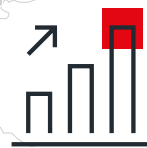

TURNOVER

**~ 500 MILLION €**

*The globally active GUTMANN Group is one of the leading producers of high-quality aluminium products for the construction and processing industries.*

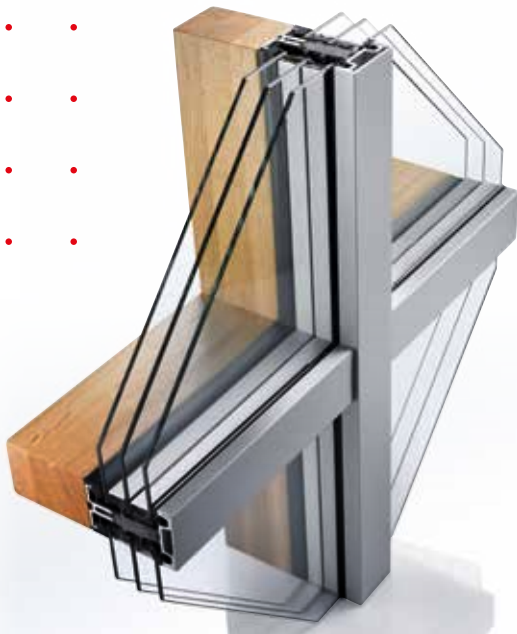

PRODUCTION

**65.000 TONNES**

